

New Calibration Light-Source

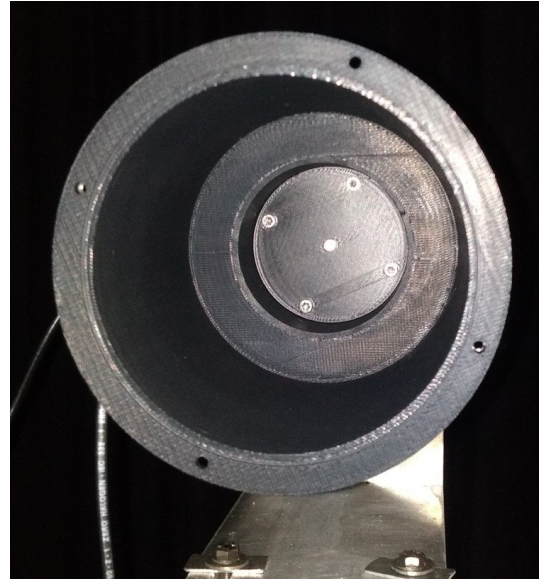

- First prototype
- Single LED on optical axis
- 10 cm diameter
 - Reduces measuring time at FDs

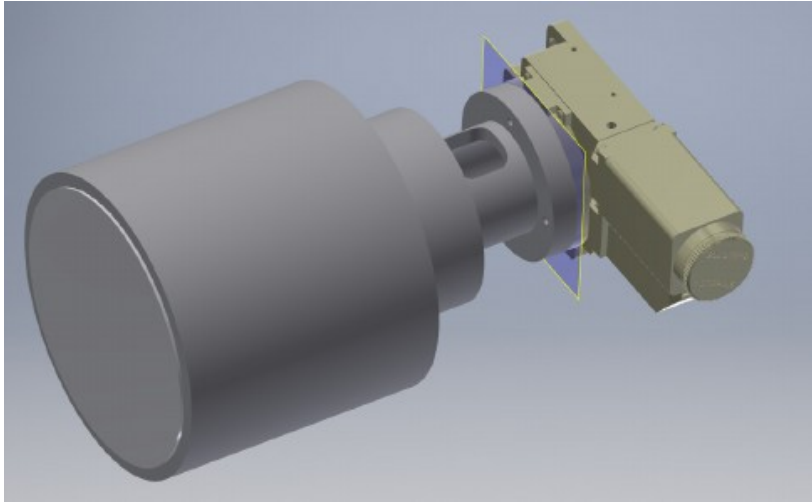
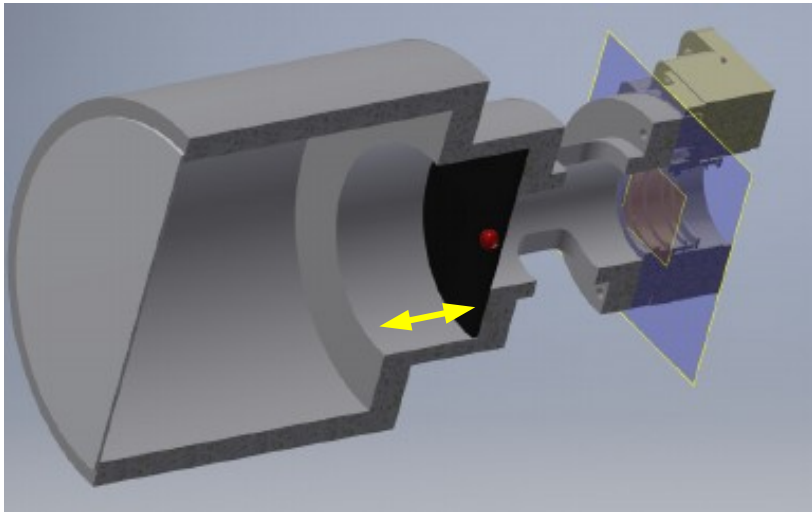

- 3D printed tube
- Constructed by M. Riegel

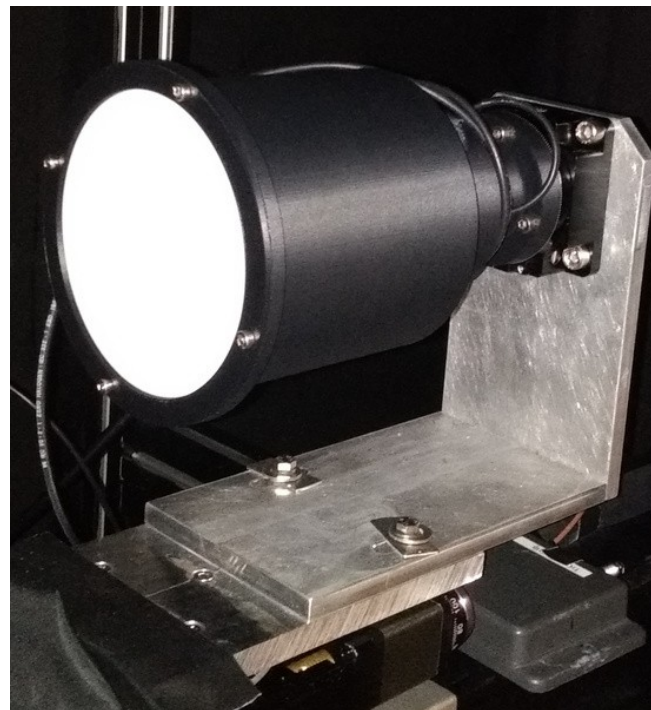

- LED powered by Copter/CB electronics
- Different diffusers can be mounted
- Distance between LED and diffuser adjustable

Emission Patterns

KIT Sphere

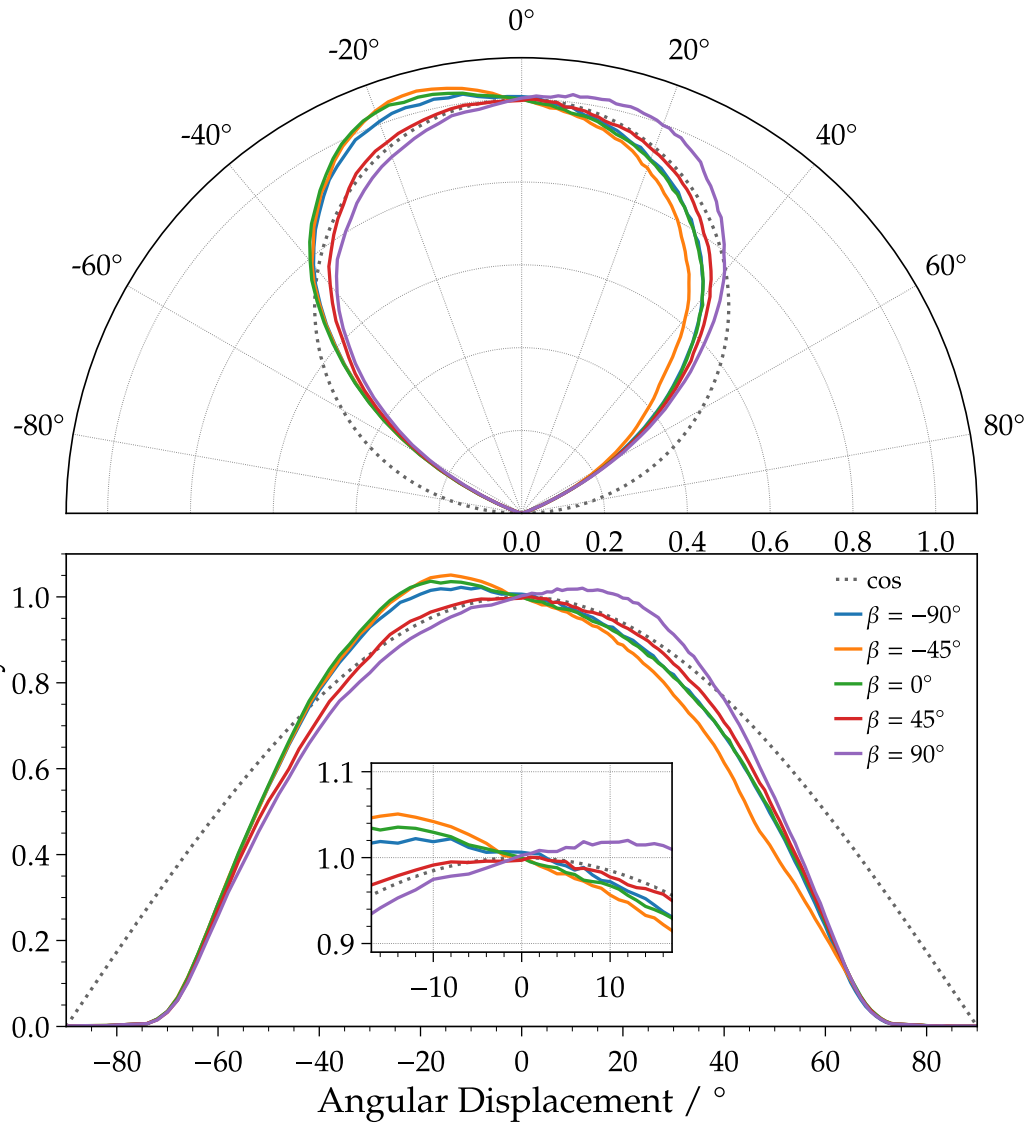

New LS with "Broadband Hybrid Diffuser"

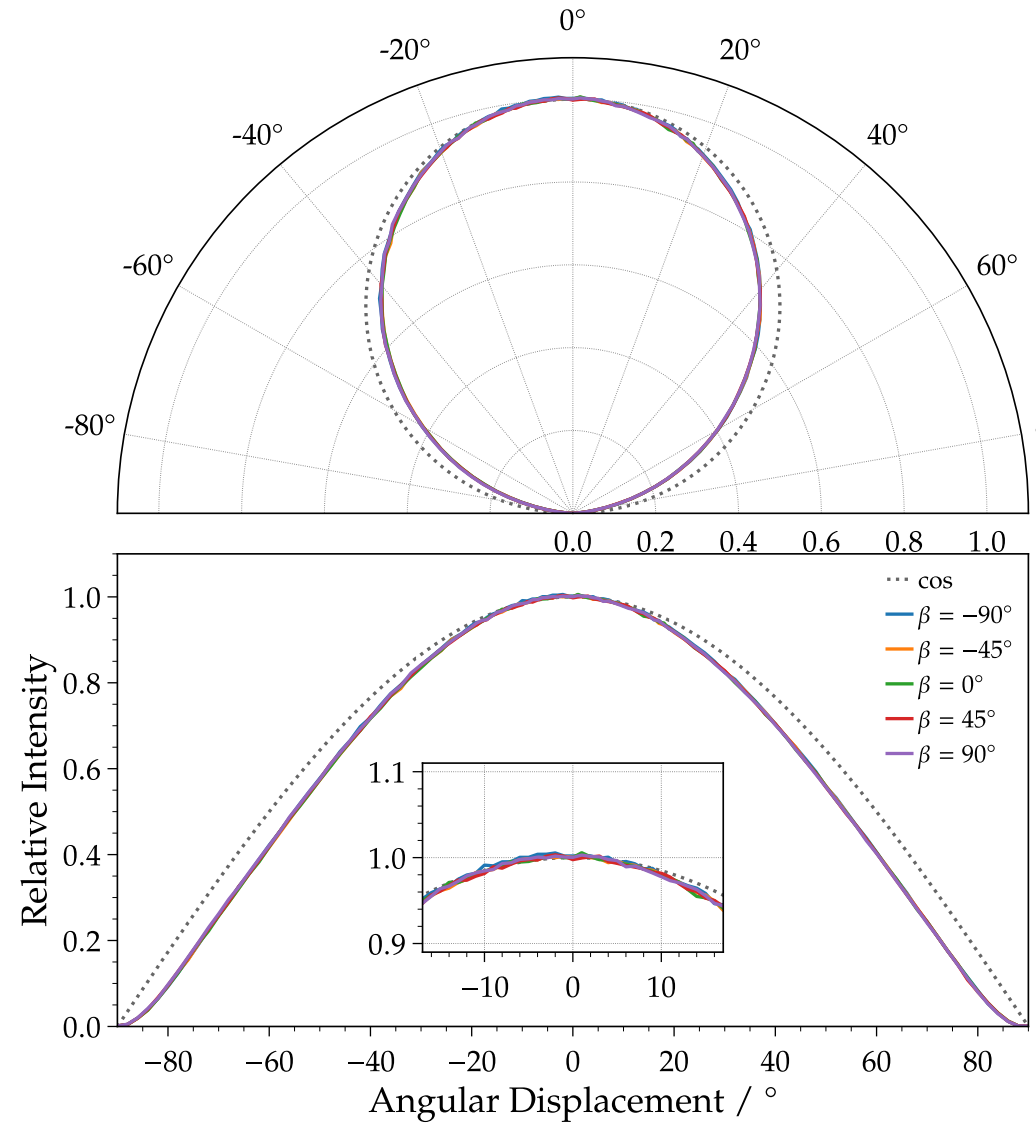

Emission Patterns

KIT Sphere

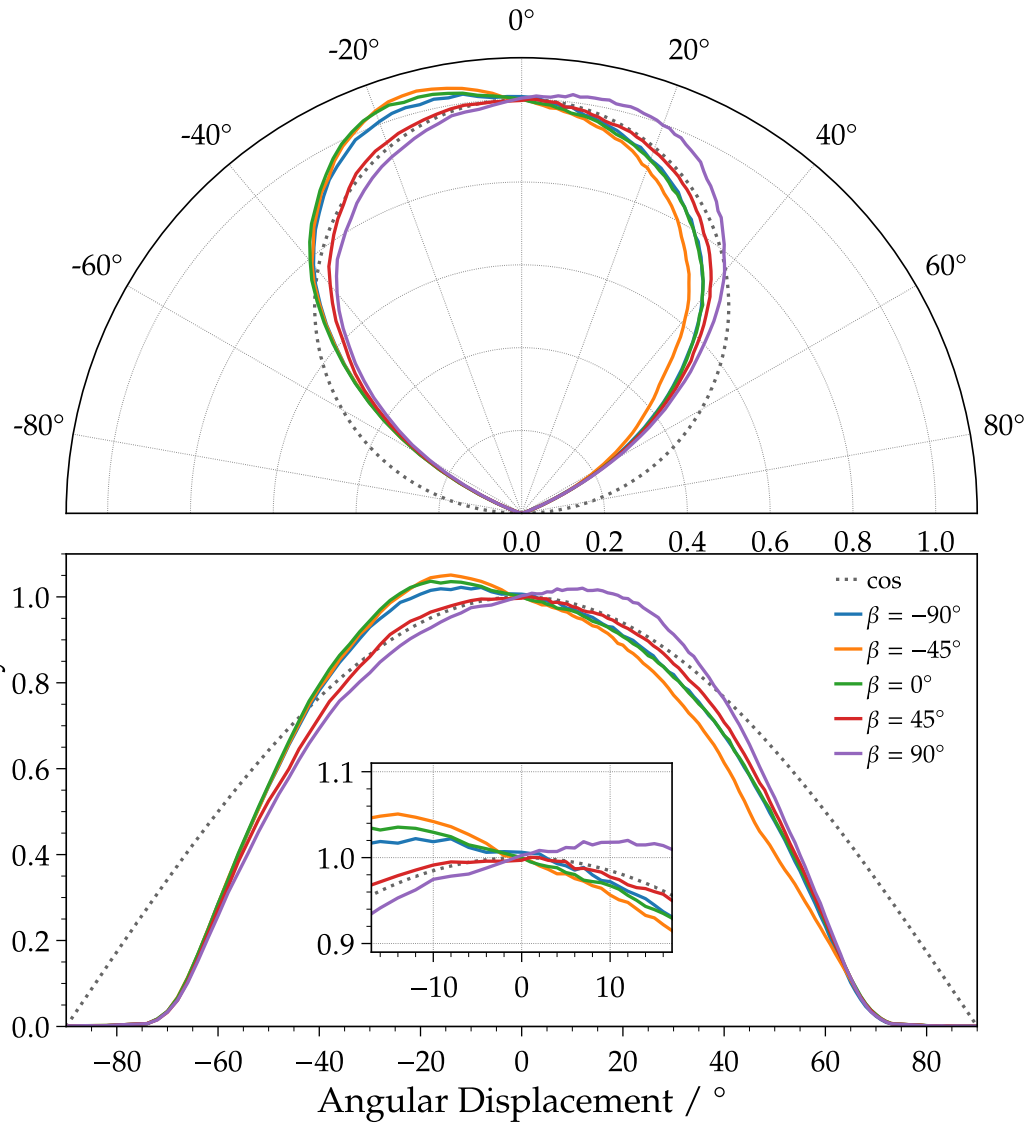

New LS with "White Diffuser Glass"

